

Description

Digital load display is a safety device to display the load carried by the crane/lifting device with the help of an input from a load transducer/load cell.

Its large size allows for viewing from longer distances and the device can be safely mounted at a remote position.

The device is connected to the Safeload Indicator which features in-built relays for protection from overloading. It may also be useful for rope slack detection. The relays can be wired to the lifting contactor or alarm or as required.

Use of this device helps reduce rope breakages, costly downtime of crane, maintenance and repairs, thus improving safety in the workplace and maintaining high levels of efficiency.

Digital Load Display

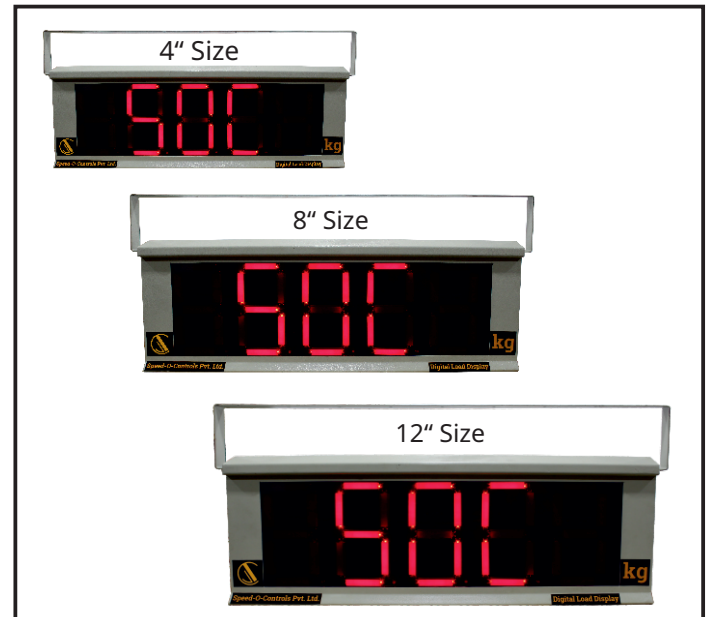

Specifications

- LED Display, Red, with 5 Digits.
- Digit Height 4 inch, 8inch, 12 inch available.
- Sheet Metal Housing
- Working temperature: from -20 to 70 °C
- Power supply via 90 - 240Vac.
- Maximum visibility and high performance visor
- Indicator specially designed and manufactured to be used in new static and dynamic systems of weighing in industrial environments.
- Tare option on front panel or by remote control.
- Rs485 Communication (2 Wire) with Safeload

Applications

- Load indication on overhead cranes or other lifting devices
- Weighing indication at long distance
- Overload Protection
- Rope Slack prevention
- Audio Indication interfacing for overload.
- High Accuracy, weighing with 32bit ADC

Dimensions

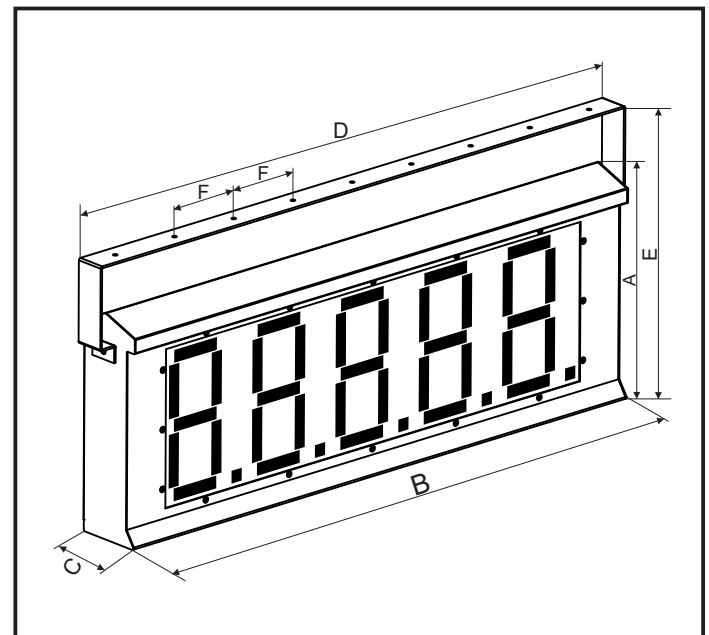

SIZE	A	B	C	D	E	F
4"	190	492	98	545	264	100
8"	303	830	98	886	377	100
12"	418	1112	98	1165	492	100

Speed-O-Controls Pvt. Ltd.

Unit - I : C-15/16, Nand Jyot Industrial Estate, Andheri-Kurla Road, Mumbai - 400072,
Tel : (022) 42469700-30
Fax : (022) 42469797
E-mail : sales@socgroup.in

Unit - II: Plot No. 4912, G. I. D. C., Phase IV, Vatva, Ahmedabad - 382445
Tel.: (079) 40083201/2/3/4,
Fax : (079) 25841056,
E-mail : sales.amd@socgroup.in

Visit us at :
www.speedocontrols.com
www.socremote.com

