

Features

- Capacity - 10,000 Kg
- Red LED Display with 5 digits and display size of 30mm height
- Cast-Steel Housing with Satin finish
- Integrated Load cell and measuring circuit.
- Standard bow shackle dimension.
- Standard eye hook dimension.
- Infrared remote control.
- Rechargeable battery.

Functions

- Zero.
- Tare.
- Hold.
- Battery Supervision.
- Overload Alarm/Record.
- Digital Calibration.
- 3-point Calibration.
- Unit Switch.
- Resolution Switch.
- Gravity acceleration set.

Specification

Max. Capacity (T)	10 T
Min. Capacity (Kg)	100Kg
Division (Kg)	5Kg
Net Weight	31Kg
Accuracy Class	OIML III
Tare Range	100%F.S.
Zero Range	4%F.S.
Safe Overload	120%F.S.
Ultimate Overload	400%F.S.
Overload Alarm	100%F.S.+9e
Battery	6V/4Ah
Adaptor	DC9V
Battery life	>80h
Temperature range	-10°C~40°C

Electronic Dynamometer



Dimensions:

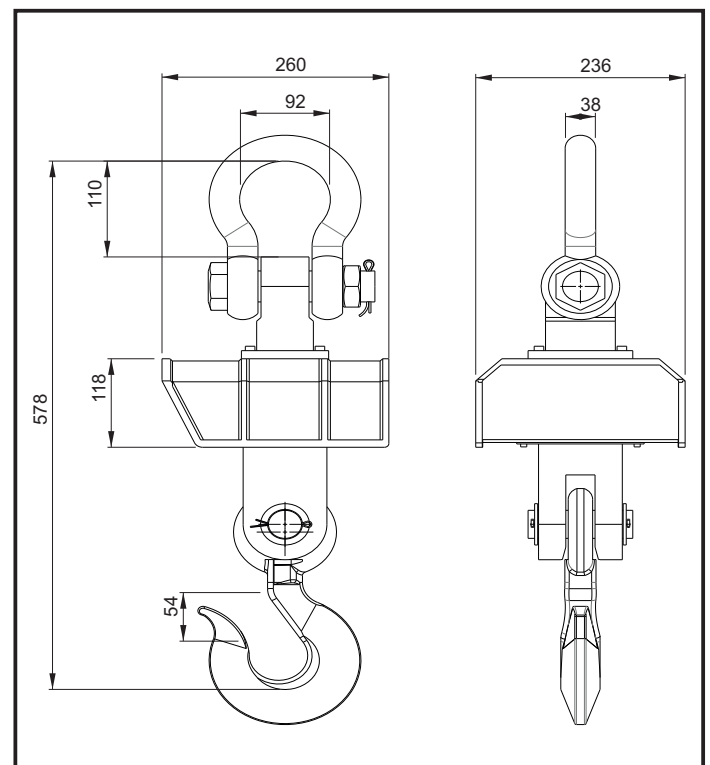

Speed-O-Controls Pvt. Ltd.

H. O. Unit - I : C-15/16, Nand Jyot Industrial Estate, Andheri-Kurla Road, Mumbai - 400072 ,
Tel : (022) 42469700-30
Fax : (022) 42469797
E-mail : sales@socgroup.in

Unit - II: Plot No. 4912, G. I. D. C., Phase IV, Vatva, Ahmedabad - 382445
Tel.: (079) 40083201/2/3/4,
Fax : (079) 25841056,
E-mail : sales.amd@socgroup.in

Visit us at :
www.speedocontrols.com
www.socremote.com

