

# CRANE SCALE (SPLASH)



## Features

- Capacity - 1,000 Kg - 5,000 Kg
- Red LED Display with 5 digits and display size of 30mm
- Aluminum Die Cast Housing with Satin finish
- Integrated Load cell and measuring circuit.
- Standard bow shackle dimension.
- Standard eye hook dimension.
- Infrared remote control.
- Rechargeable battery.

## Functions

- Zero.
- Tare.
- Hold.
- Battery Supervision.
- Overload Alarm/Record.
- Digital Calibration.
- 3-point Calibration.
- Unit Switch.
- Resolution Switch.
- Gravity acceleration set.

## Specification

Max. Capacity (T)	1T, 3T, 5T
Min. Capacity (Kg)	100Kg
Division (Kg)	5Kg
Net Weight	31Kg
Accuracy Class	OIML III
Tare Range	100%F.S.
Zero Range	4%F.S.
Safe Overload	120%F.S.
Ultimate Overload	400%F.S.
Overload Alarm	100%F.S.+9e
Battery	6V/4Ah
Adaptor	DC7.2V
Battery life	>80h
Temperature range	-10°C~40°C

## Electronic Dynamometer



## Dimensions:

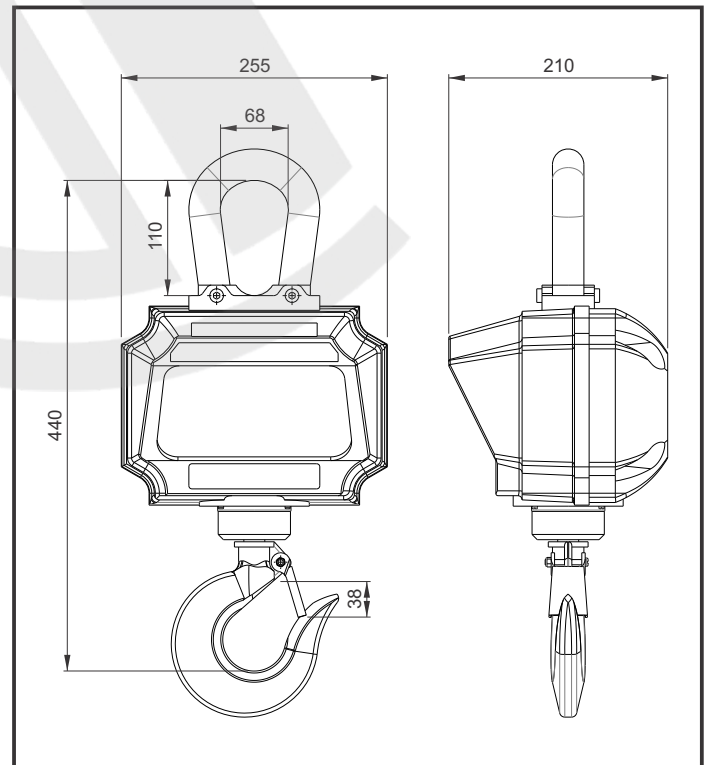

H. O. Unit - I: C-15/16, Nand Jyot Industrial Estate, Andheri-Kurla Road, Mumbai - 400072,  
Tel.: (022) 42469700-30  
E-mail: sales@socgroup.in  
Visit us at : www.speedocontrols.com , www.socremote.com

Unit - II: Plot No. 4912, G. I. D. C., Phase IV, Vatva, Ahmedabad - 382445  
Tel.: (079) 68169700/702/712,  
E-mail: enquiry2@socgroup.in

**SPEED-O-CONTROLS**  
**PVT. LTD.**  
**LOADCELL SOLUTIONS**

JAN, 2020