

CRANE SCALE (HIGH TEMP)

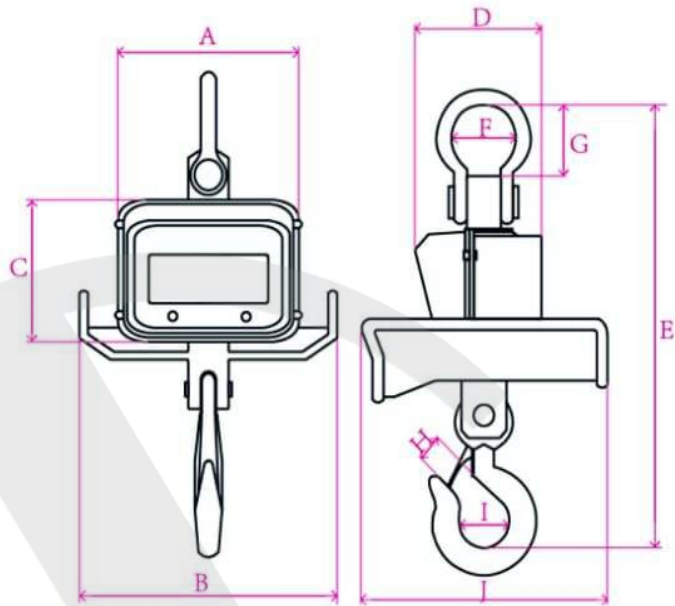

Model	Capacity kg	Division kg	Counts	Dimension mm							Weight kg
				A	B	C	D	E	F	G	
OCS-3T	3000	1	3000	270	158	620	104	65	43	50	31
OCS-5T	5000	2	2500	270	158	700	115	84	55	65	31
OCS-10T	10000	5	2000	270	158	800	135	102	65	80	41
OCS-15T	15000	5	3000	270	190	900	188	116	65	80	62
OCS-20T	20000	10	2000	320	200	1100	230	140	85	100	85
OCS-30T	30000	10	3000	320	200	1200	165	145	117	127	115
OCS-50T	50000	20	2500	420	310	1600	390	233	130	160	338

Iron temp	1000°C	1200°C	1400°C	1500°C
Safe distance	1200mm	1500mm	1800mm	2000mm

Accuracy	OIML Ⓛ
Tare range	100% F.S.
Stable time	5-8s
Overload alarm	110% F.S.
Safe overload	125% F.S.
Ultimate load	400% F.S.
Power	Fully sealed maintenance - free rechargeable battery 6V / 4AH
Display	LED/LCD
Operation temp	-10°C ~ +40°C

* Features :

- ★ NEW: New circuit design, standby time longer and more stable
- ★ FAST: High-quality integrated load cell, weighing fast, accurate and stable
- ★ GOOD: High-quality sealed maintenance-free rechargeable battery, high-strength impact resistant aluminum alloy case
- ★ STABLE: Perfect software, no crash, no hops
- ★ BEAUTIFUL: Stylish appearance, patented design
- ★ SAVE: Handheld remote control, convenient and strong function

H. O. Unit - I : C-15/16, Nand Jyot Industrial Estate, Andheri-Kurla Road, Mumbai - 400072,
Tel : (022) 42469700-30
E-mail : sales@socgroup.in
Visit us at : www.speedocontrols.com , www.socremote.com

Unit - II: Plot No. 4912, G. I. D. C., Phase IV, Vatva, Ahmedabad - 382445
Tel.: (079) 68169700/702/712,
E-mail : enquiry2@socgroup.in

SPEED-O-CONTROLS
PVT. LTD.

LOADCELL SOLUTIONS

JAN, 2020