

# CRANE SCALE (HEAVY DUTY)



## Features

- NEW : New PCB design and longer standby time.
- QUICK : Integral design of load cell. Quick, accurate and stable weighing.
- STURDY : High quality rechargeable battery and Shock-resistant high-strength metallic casing.
- STABLE : Software is stable and ensures continuous operation.
- ACCURATE : New Circuit design, longer standby time and reliable. Special one sensor design, fast weighing with accuracy.

## Specification

Display	5 Digit, 30mm LED
Setting Time	5-8s
Control Distance	≤ 20m
Battery	Rechargeable 6V/4AH
Tare Range	100%F.S.
Overload Warning	110%F.S.
Limit Load	400%F.S.
Temperature	-10°C ~ +40°C

## Dimensions

Capacity		20T	30T	50T
Full Scale (Kg)		20000	30000	50000
Division (Kg)		10	10	20
Number of Divisions		2000	3000	2500
Dimensions (mm)	A	308	308	468
	B	200	200	317
	C	296	296	480
	D	1000	1100	1450
	E	147	155	250
	F	124	140	233
	G	105	125	160
	H	80	80	130
Weight (Kg)		85	115	338

Crane Scale



Electronic Dynamometer

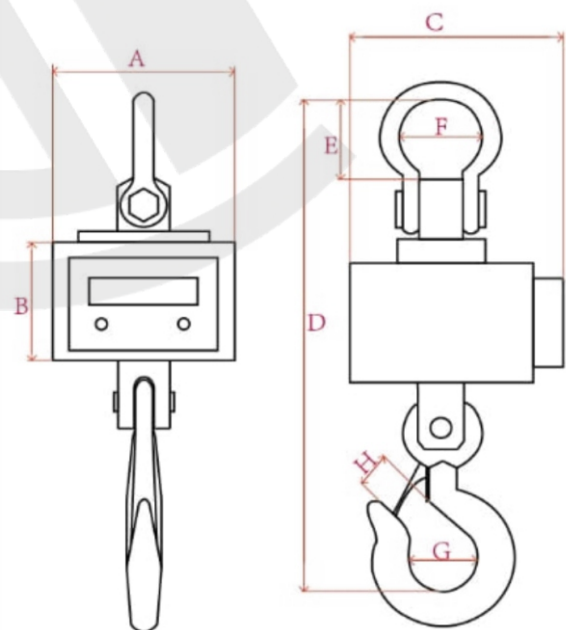

H. O. Unit -I : C-15/16, Nand Jyot Industrial Estate, Andheri-Kurla Road, Mumbai - 400072 ,  
Tel : (022) 42469700-30  
E-mail : sales@socgroup.in  
Visit us at : www.speedocontrols.com , www.socremote.com

Unit - II: Plot No. 4912, G. I. D. C., Phase IV, Vatva, Ahmedabad - 382445  
Tel.: (079) 68169700/702/712,  
E-mail : enquiry2@socgroup.in

**SPEED-O-CONTROLS**  
**PVT. LTD.**  
**LOADCELL SOLUTIONS**

JAN, 2020