

Features

- NEW : New PCB design and longer standby time.
- QUICK : Integral design of load cell. Quick, accurate and stable weighing.
- STURDY : High quality rechargeable battery and Shock-resistant high-strength metallic casing.
- STABLE : Software is stable and ensures continuous operation.
- ACCURATE : New Circuit design, longer standby time and reliable. Special one sensor design, fast weighing with accuracy.

Specification

Display	5 Digits, 30mm RED LED
Setting Time	5-8s
Control Distance	<20m
Battery	Rechargeable 6V/4AH
Tare Range	100%F.S.
Overload Warning	110%F.S.
Limit Load	400%F.S.
Temperature	-10°C ~ +40°C

Optional : Wireless Display, 5 Digit, 8 mm size, Red LED, Range 50m

Capacity kg	2000	3000	5000	10000	15000	
Accuracy kg	1	1	2	5	5	
D I M E N S I O N mm	A	210	210	210	210	210
	B	170	170	170	170	170
	C	205	205	205	205	205
	D	530	530	620	660	740
	E	76	76	88	114	128
	F	63	63	78	92	97
	G	46	46	60	71	80
	H	40	40	52	55	68

Crane Scale

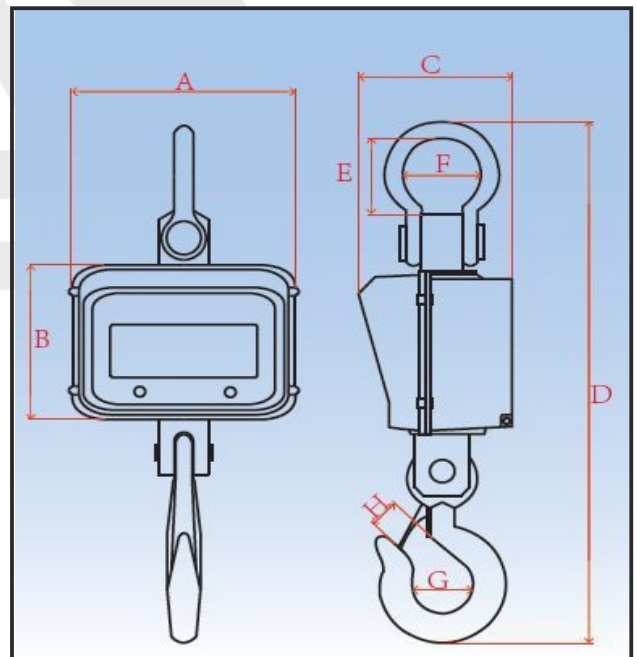

H. O. Unit - I : C-15/16, Nand Jyot Industrial Estate, Andheri-Kurla Road, Mumbai - 400072,
Tel : (022) 42469700-30
E-mail : sales@socgroup.in
Visit us at : www.speedocontrols.com , www.socremote.com

Unit - II : Plot No. 4912, G. I. D. C., Phase IV, Vatva, Ahmedabad - 382445
Tel.: (079) 68169700/702/712,
E-mail : enquiry2@socgroup.in

SPEED-O-CONTROLS PVT. LTD.
LOADCELL SOLUTIONS

JAN, 2020